

lana'



**LANOVÉ VODIČE
ŤAHANÉ RÚRKY
STRANDED CONDUCTORS
DRAWN TUBES
*LEITUNGSSEILE
ROHRE GEZOGEN***



Lana'

**Jedinečná voľba
pre dodávky vodičov s najvyššími parametrami**

Nadväzujeme so skúseným tímom na dlhodobú tradíciu výroby vodičov pre diaľkový prenos elektrickej energie.

Podporujeme zámery investorov pri obnove a budovaní prenosových a distribučných sietí inovatívnymi produktami vyrábanými na najmodernejšej technológii.

Rozvíjame vlastné know-how v partnerstve s renomovanými vývojovými inštitúciami.

Ťaháme spolu za jedno lano



Lana'

**Unique choice
to delivery conductors with the highest parameters**

We continue with an experienced team in the long tradition of production of conductors for long-distance transmission of electricity.

We support of the investors projects in the reconstruction and building of transmission and distribution networks supplying innovative products manufactured on the most modern technology.

We develop our own know-how, in partnership with reputable R&D institutions.

Be on one line



HLINÍKOVÉ DRÔTY
CELOHLINÍKOVÉ VODIČE
HLINÍKOVÉ JADRÁ KÁBLOV-KOMPRIMOVANÉ
HLINÍKOVÉ JADRÁ KÁBLOV-SEKTOROVÉ
HLINÍKOVÉ LANÁ VYSTUŽENÉ OCELOU
VODIČE ZO ZLIATINY AL
HLINÍKOVÉ RÚRKY ŤAHANÉ
ZLIATINOVÉ RÚRKY ŤAHANÉ



ALUMINIUM DRAWN WIRES
ALL ALUMINIUM CONDUCTORS
ALL ALUMINIUM CONDUCTORS-COMPRESSED
ALL ALUMINIUM CONDUCTORS-SECTIONAL
ALUMINIUM CONDUCTORS STEEL REINFORCED
ALL ALUMINIUM ALLOY CONDUCTORS
ALUMINIUM DRAWN TUBES
ALUMINIUM ALLOY DRAWN TUBES



ALUMINIUMDRÄHTE
ALUMINIUMSEILE EINFACHE
ALUMINIUMSEILE KOMPRIMIERTE
ALUMINIUM SEKTORSEILE
ALUMINIUMSEILE MIT STEHLSEILE
LEGIERUNG ALUMINIUMSEILE
ALUMINIUMROHRE GEZOGEN
LEGIERUNG ALUMINIUMROHRE GEZOGEN

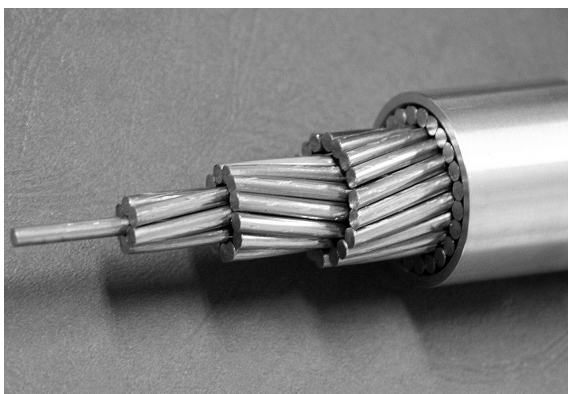

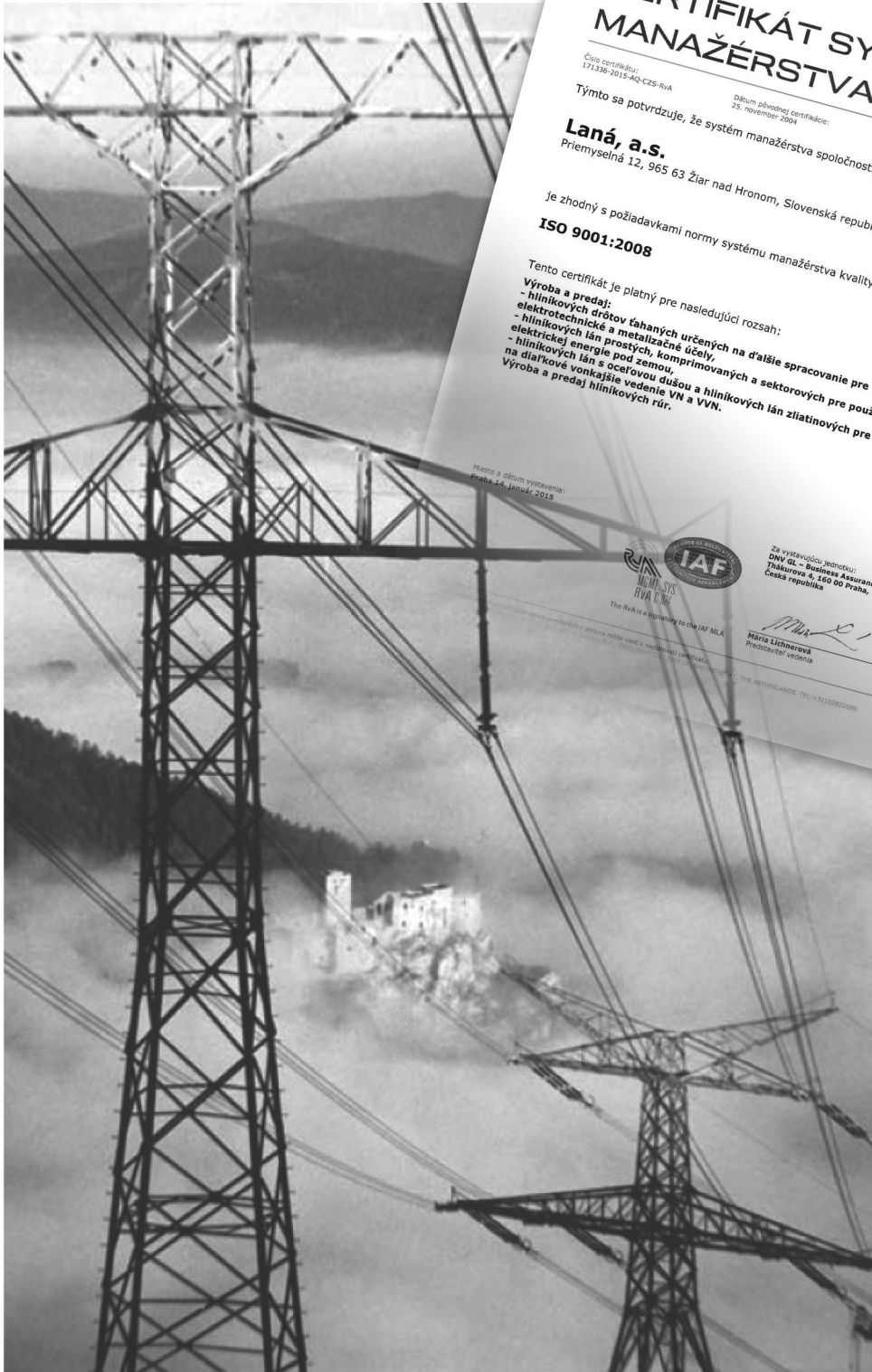



Hliníkové drôty ťahané.....	4
Celohliníkové vodiče, hliníkové jadrá káblov komprimované a sektorové.....	5
Hliníkové laná vystužené oceľou	6
Typické konštrukcie AlFe lán	7
Tabuľková časť AlFe lán	8
Tabuľková časť Al lán sektorových	17
Tabuľková časť Al lán komprimovaných.....	18
Tabuľková časť Al lán prostých	19
Tabuľková časť Al lán zliatinových	21
Balenie	23
Spôsoby mazania lanových vodičov	25
Al rúrky ťahané	26
Zliatinové rúrky ťahané	27
Aluminium drawn wires	4
All Aluminium conductors, compressed and sectional	5
Aluminium conductors steel reinforced	6
Typical ACSR structure	7
Tables of ACSR	8
Tables of AAC sectional	17
Tables of AAC compressed.....	18
Tables of AAC.....	19
Tables of AAAC.....	21
Packing.....	23
Aplication of grease to stranded conductors	25
Aluminium drawn tubes	26
Aluminium alloy drawn tubes	27
<i>Aluminiumdrähte gezogen.....</i>	<i>4</i>
<i>Aluminiumseile einfache, komprimierte und Sektorseile.....</i>	<i>5</i>
<i>Aluminiumseile mit Stahlseile.....</i>	<i>6</i>
<i>Typische ACSR-Seilkonstruktionen</i>	<i>7</i>
<i>Tabellen Aluminiumseile mit Stahlseile</i>	<i>8</i>
<i>Tabellen Aluminium sektorseile</i>	<i>17</i>
<i>Tabellen Aluminiumseile komprimierte.....</i>	<i>18</i>
<i>Tabellen Aluminiumseile einfache.....</i>	<i>19</i>
<i>Tabellen Aluminium legierung seile</i>	<i>21</i>
<i>Packung.....</i>	<i>23</i>
<i>Die Schmierung der Seile</i>	<i>25</i>
<i>Aluminiumrohre gezogen.....</i>	<i>26</i>
<i>Legierung Aluminiumrohre gozogen</i>	<i>27</i>



Hliníkové drôty ťahané

Aluminium drawn wires

Aluminiumdrähte gezogene



Hliníkové drôty ťahané sú určené na ďalšie spracovanie pre rôzne elektrotechnické a metalizačné účely. Používajú sa priamo na výrobu hliníkových lán prostých, komprimovaných, sektorových a ocelovo-hliníkových lán a sú tiež určené pre ďalšie spracovanie u odberateľov na výrobu káblov, prípadne iných vodičov.

Al drôty sa vyrábajú z elektrovodného hliníka – Al 99,5% v priemeroch 1,6–11,5 mm.

Normy:

EN 60889, EN 50183

STN 424004, DIN 48200T5 E-Al

Hliník tvárnený pre elektrotechniku AL 99,5

stav mäkký STN 424004.11 a stav polotvrdý STN 424004.21 - len do priemeru 4,5 mm (dodávky v kruhoch), stav tvrdý STN 424004.31 v celom rozmerovom sortimente

STN 427410

Drôty kruhové z hliníka a zliatin hliníka ťahané za studena – Rozmerová norma

STN 421418

Drôty kruhové z hliníka a zliatin hliníka – Technické dodacie predpisy

DIN 48203, časť 5

GOST 6132 - 79

Al drôt požadovaného priemeru je dodávaný na oceľových bubnoch a do 4,5 mm aj v kruhoch o hmotnosti 30–50 kg.

Stav mäkký STN 424004.11 a polotvrdý 424004.21 je dodávaný len v kruhoch.

Aluminium drawn wires are processed for various el. technical and metallizing purposes. They are used directly in Lanovna plant for bare, compressed, sectional aluminium conductors and steel-aluminium conductors production and also as semi-finished product for next processing at customers for cables or other leads production.

Al wires are manufactured from e. conductive aluminium-Al 99,5% with diam. of 1,6–11,5 mm.

Standards:

EN 60889, EN 50183

STN 424004, DIN 48200T5 E-Al

Aluminium, formed for e.engineering AL 99,5

soft condition STN 424004.11 and semi-hard condition STN 424004.21- only to max. diam. of 4,5 mm (supplies in rings), hard condition STN 424004.31 in full dimensional assortment.

STN 427410

Round wires from aluminium and Al alloys, cold drawn – Dimensional standard

STN 421418

Round wires from aluminium and Al alloys - technical supply regulations

DIN 48203, part 5

GOST 6132 - 79

Al wire of required diameter is delivered on steel drums and to max. 4,5 mm also in rings with weight of 30–50kg.

Soft condition STN 424004.11 and semi-hard 424004.21 is supplied in rings only.

Aluminiumdrähte gezogene sind für weitere Verarbeitung zu verschiedensten elektrotechnischen und metallisierungs-Zwecken bestimmt. Sie werden direkt im Werk Seilproduktion für die Fertigung von Aluminiumseilen einfachen, komprimierten, Sektorseilen und Stahl-Aluminiumseilen eingesetzt und sind auch für weitere Verarbeitung bei den Abnehmern für die Fertigung von Kabeln bzw. von anderen Leitern bestimmt.

Aluminiumdrähte werden aus leitfähigem Aluminium Al 99,5% von Durchmessern 1,6–11,5 mm gefertigt.

Normen:

EN 60889, EN 50183

STN 424004, DIN 48200T5 E-Al

Geformtes Aluminium für Elektrotechnik AL 99,5

weiche Ausführung STN 424004.11 und halbhart Ausführung STN 424004.21 - nur bis Durchmesser 4,5 mm (kreisförmig geliefert), harte Ausführung STN 424004.31 im vollen Bemessungssortiment

STN 427410

Kreisförmige Drähte aus Aluminium und Aluminiumlegierungen, kaltgezogene - Bemessungen

STN 421418

Kreisförmige Drähte aus Aluminium und Aluminiumlegierungen, kaltgezogene - Technische Lieferbedingungen

DIN 48203, Teil 5

GOST 6132 - 79

Der Aluminiumdraht von gewünschtem Durchmesser wird an der Stahltrommel geliefert, bis 4,5 mm auch in Ringen vom Gewicht 30–50 Kg geliefert.

Weiche Ausführung STN 424004.11 und halbhart 424004.21 wird lediglich in Ringen geliefert.





Celohliníkové vodiče, hliníkové jadrá káblov komprimované a sektorové

All Aluminium conductors, compressed and sectional
Aluminiumseile einfache, komprimierte und Sektorseile

Celohliníkové vodiče, jadrá káblov komprimované a sektorové sa používajú na vedenie elektrickej energie pod zemou. Tento druh vodičov sa spracováva u odberateľov na izolované vodiče s gumovou izoláciou, silové káble celoplastové s izoláciou PVC a pod.

Celohliníkové lano prosté má všetky drôty z hliníka a lano má kruhový prierez.

Hliníkové jadro kábla komprimované má všetky drôty z hliníka, lano má kruhový prierez zavalcovaný tvarovacími valcami.

Hliníkové jadro kábla sektorové má všetky drôty z hliníka, lano má sektorový prierez z kruhového prierezu prechodom cez tvarovacie valce.

Rozmer a počet drôtov v jednotlivých vrstvách je daný konštrukciou lana. Vyrábaný sortiment je uvedený v tabuľkovej časti. Celohliníkové vodiče a jadrá káblov sa vyrábajú podľa: EN 50182, STN 024210, TP 20-95, VDE 0295, GOST 839, DIN 48201, BS 215.

Po dohode je možné vyrobiť konštrukcie celohliníkových vodičov a jadier káblov prostých a sektorových aj podľa iných zahraničných noriem.

AAC conductors are used for el.energy conduction under ground. This type of conductors is processed by customers to insulated wires with rubber insulation, full-plastic power cables with PVC insulation, etc.

All Aluminium conductors has all the wires from aluminium and conductors has a round cross section.

All Aluminium conductors compressed has all the wires from aluminium, conductors has a round cross section, rolled by forming rollers.

All Aluminium conductors sectional has all the wires from aluminium and conductors has the sectional cross section, obtained from round cross section after passing the forming rollers.

Dimension and number of wires in individual coats is dependent on conductors structure. Produced assortment is listed in table part. All Aluminium conductors are manufactured in accordance with following standards:

EN 50182, STN 024210, TP 21-95, VDE 0295, GOST 839, DIN 48201, BS 215.

After agreement, it is possible to manufacture bare and sectional Al conductors in accordance with foreign standards.

Aluminiumseile einfache, komprimierte und Sektorseile werden zur Elektroleitungen im Untergrund eingesetzt. Diese Seile werden bei Abnehmern zu isolierten Leitern mit Gummi-Isolierung, vollständigen Kunststoffkabeln mit PVC-Isolierung usw. weiter verarbeitet.

Das Aluminiumseil einfache hat alle Drähte aus Aluminium und sein Querschnitt ist kreisförmig.

Das Aluminiumseil komprimierte hat alle Drähte aus Aluminium, sein Querschnitt ist kreisförmig, durch Formwalzen eingewalzt.

Das Sektorseil hat alle Drähte aus Aluminium, sein Querschnitt ist geformt aus kreisförmigen durch sein Durchgang über Formwalzen..

Die Bemessungen und Anzahl von Drähten in den einzelnen Lagen ist durch die Bauart des Seiles gegeben. Das Produktionssortiment ist aus der Tabelle ersichtlich. Die Aluminiumseile werden nach EN 50182, STN 024210, TP 21-95, VDE 0295, GOST 839, DIN 48201, BS 215 gefertigt.

Nach Vereinbarung können Aluminiumseile einfache und Sektorseile auch nach anderen ausländischen Normen gefertigt werden.

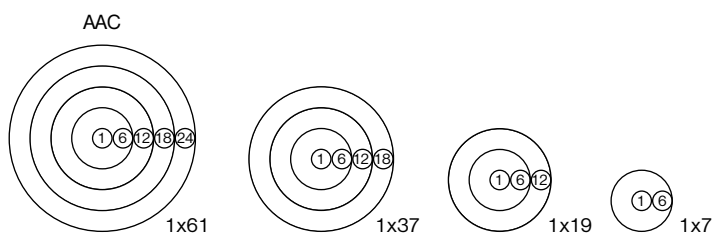

Hliníkové laná vystužené ocelou

Aluminium conductors steel reinforced
Aluminiumseile mit Stahseile

AIFe
ACSR



AIFe laná sa používajú na diaľkové vonkajšie elektrické vedenie vvn, vn. Hliníkové lano s oceľovou dušou je konštruované tak, že dušu lana tvorí oceľový pozinkovaný drôt alebo lano a vonkajšie vrstvy sú z hliníkových drôtov. AIFe laná sa vyrábajú jednovrstvové až štvorvrstvové.

Normy:

EN 50182, PN ZSNP 1/83, STN 024210, GOST 839, DIN 48 204, BS 215, ASTM B 232. Po dohode je možné vyrobiť konštrukcie AIFe lán aj podľa iných zahraničných noriem.

AIFe lano je dodávané na oceľových, prípadne drevených bubnoch, malé prierezy aj v kruhoch. Vyrábaný sortiment AIFe lán je uvedený v tabuľkovej časti.

ACSR conductors are used for overhead lines. Aluminium conductors steel reinforced is designed so, that galvanized wire or conductors constitutes the core of the conductors and external coats are from aluminium wires. ACSR conductors are produced from single coated to max. four coats.

Standards:

EN 50182, PN ZSNP 1/83, STN 024210, GOST 839, DIN 48 204, BS 215, ASTM B 232. After agreement, it is possible to manufacture ACSR conductors designs in accordance with foreign standards.

ACSR conductors is delivered on steel or wooden drums, small diameters also in rings. Manufactured assortment of ACSR conductors is listed in table section.

Die ACSR Seile werden für äußere UHtrahoch- und Hochspannung-Fernleitungen eingesetzt. Das Aluminiumseil mit Stahlseile ist derartig konstruiert, daß die Stahlseile ein verzinkter Draht oder Seil bildet, und die Außenlitzten aus Aluminiumdrähten bestehen. Die ACSR Seile werden zwei- bis vierlagig produziert.

Normen:

EN 50182, PN ZSNP 1/83, STN 024210, GOST 839, DIN 48 204, BS 215, ASTM B 232 und auch nach anderen ausländischen Normen zu produzieren.

Das ACSR Seil wird geliefert an Stahl- bzw. Holztrommeln, kleinere Durchschnitte auch in Ringen. Das Sortiment von ACSR Seilen ist aus der Tabelle ersichtlich.

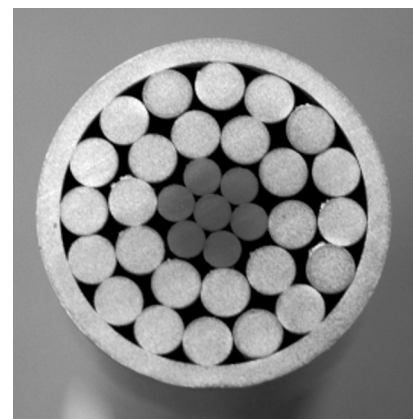
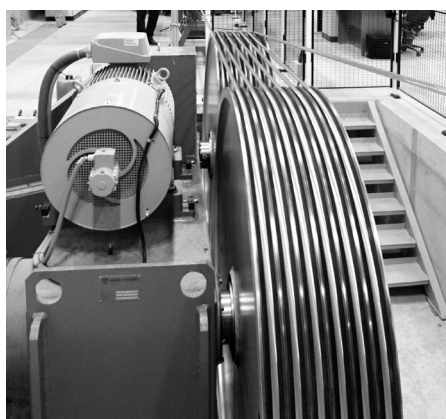
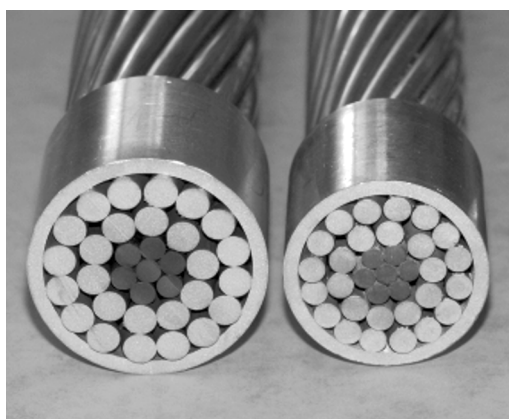



AlFe
ACSR

Typické konštrukcie
Typical structure
Typische Seilkonstruktionen

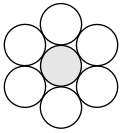

6Al/1Fe

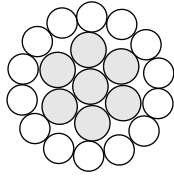

14Al/7Fe

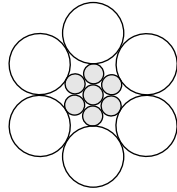

6Al/7Fe

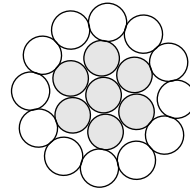

12Al/7Fe

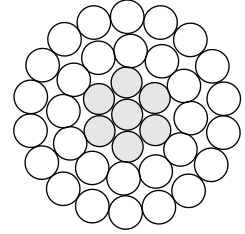

30Al/7Fe

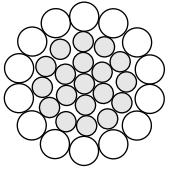

14Al/19Fe

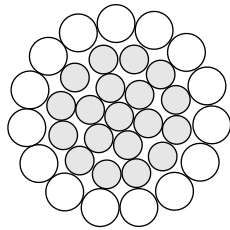

15Al/19Fe

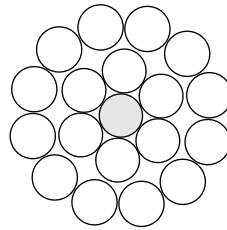

18Al/1Fe

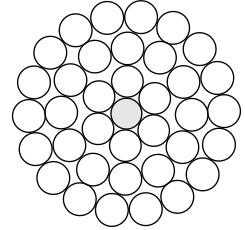

36Al/1Fe

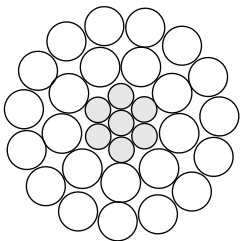

24Al/7Fe

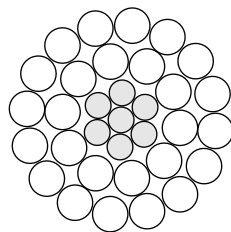

26Al/7Fe

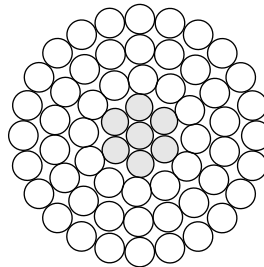

54Al/7Fe

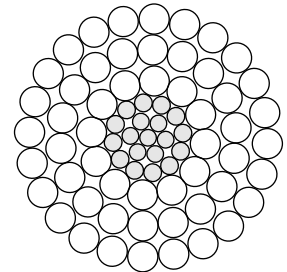

54Al/19Fe

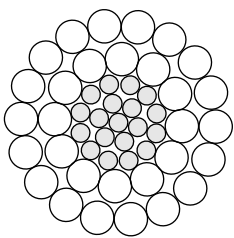

30Al/19Fe

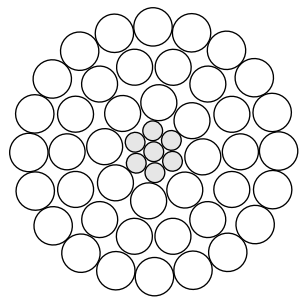

42Al/7Fe

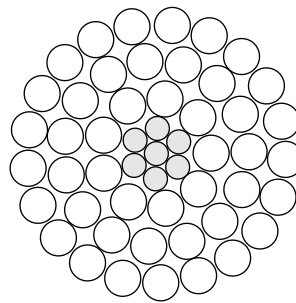

45Al/7Fe

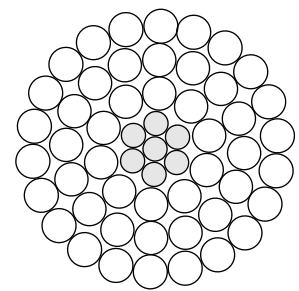

48Al/7Fe

Vlastnosti doporučených vodičů pro venkovní vedení s napětím nad 45 kV AC – Typ AL1/ST1A

PNE 34 7509
Tabulka G.1



Označení	Průřez		Počet drátů		Průměr drátů		Průměr		Hmotnost na jednotku délky (bez maziva)	Hmotnost na jednotku délky vč. maziva ¹⁾	Jmenovitá pevnost	DC odpor	Konečný modul pružnosti	Součinitel délkové roztažnosti
	AL	ST	AL	ST	AL	ST	Duše	Celkový						
	mm ²	mm ²	mm ²	mm ²	mm	mm	mm	mm	kg/km	kg/km	kN	Ω/km	MPa	1/K
122-AL1/20-ST1A	121,6	19,8	141,4	10+16	1+6	2,44	1,90	5,70	15,5	491,0	494,9	0,237 6	74 200 *	1,89E-05
119-AL1/42-ST1A	118,8	41,6	160,4	15+21	1+6	2,05	2,75	8,25	16,5	653,9	662,1	0,243 5	90 000	1,67E-05
122-AL1/71-ST1A	122,1	71,3	193,4	12	1+6	3,60	3,60	10,8	18,0	894,5	908,7	0,236 4	104 700	1,53E-05
183-AL1/43-ST1A	183,4	42,8	226,2	12+18	1+6	2,79	2,79	8,37	19,5	841,6	850,1	0,157 6	80 500	1,79E-05
184-AL1/30-ST1A	183,8	29,8	213,6	10+16	1+6	3,00	2,33	6,99	19,0	741,0	747,0	0,157 1	74 200 *	1,89E-05
212-AL1/49-ST1A	212,1	49,5	261,5	12+18	1+6	3,00	3,00	9,00	21,0	973,1	982,9	0,136 3	80 500	1,79E-05
243-AL1/39-ST1A	243,1	39,5	282,5	10+16	1+6	3,45	2,68	8,04	21,8	980,1	988,0	0,118 8	74 200 *	1,89E-05
362-AL1/59-ST1A	361,9	59,1	421,1	10+16	1+6	4,21	3,28	9,84	26,7	1 462,2	1 473,9	0,079 8	74 200 *	1,89E-05
382-AL1/49-ST1A	381,7	49,5	431,2	12+18+24	1+6	3,00	3,00	9,00	27,0	1 442,5	1 452,3	0,075 8	67 100 *	1,94E-05
434-AL1/56-ST1A	434,3	56,3	490,6	12+18+24	1+6	3,20	3,20	9,60	28,8	1 641,3	1 652,4	0,066 6	67 100 *	1,94E-05
490-AL1/64-ST1A	490,3	63,6	553,8	12+18+24	1+6	3,40	3,40	10,2	30,6	1 852,9	1 865,5	0,059 0	67 100 *	1,94E-05
679-AL1/86-ST1A	678,6	86,0	764,5	12+18+24	1+6+12	4,00	2,40	12,0	36,0	2 549,7	2 568,6	0,042 6	69 700 *	1,95E-05
758-AL1/43-ST1A ²⁾	758,1	43,1	801,2	12+18+18+24	1+6	2,90 4,12	2,80	8,40	36,5	2 436,4	2 445,0	0,038 2	62 300	2,11E-05

1) Hmotnost vodiče s mazanou duší, stanovená podle přílohy B EN 50182 pro případ mazání (1).

2) Vodič, doporučený pouze pro použití v rozvodnách. Konstrukce vodiče (30+42 AL drátů a 7 ST drátů) není v tabulkách 4 a D.1 EN 50182 uvedena. Pro výpočet přírůstků v důsledku slábní jsou použity stájecí poměry, uvedené v tab. D.1 pro vodiče se stejným počtem vrstev AL a ST drátů (72 AL+7 ST drátů, 84 AL+7 ST drátů). Přírůstky v důsledku slábní (doplnění PNE 34 7509 v tab. 4): hmotnost oceli 0,52%, hmotnost a elektrický odpor hliníku 2,45%.

Směr vnitřní vrstvy všech vodičů pravotočivý (Z).

Hodnoty konečného modulu pružnosti, označené *, jsou typické hodnoty podle IEC/TR 61597 pro danou konstrukci. Ostatní hodnoty modulu pružnosti a teplotního součinitele délkové roztažnosti jsou stanoveny výpočtem podle IEC/TR 61597.



Tabulka G.2 Vlastnosti doporučených vodičů pro venkovní vedení s napětím nad 45 kV AC – Typ AL1/ST6C

Označení	Průřez		Počet drátů		Průměr drátů		Průměr		Hmotnost na jednotku délky (bez maziva)	Hmotnost na jednotku délky vč. maziva ¹⁾	Jmenovitá pevnost	Dc odpor	Konečný modul pružnosti	Součinitel délkové roztažnosti	
	AL	ST	Celkový	AL	ST	AL	ST	důše							celkový
	mm ²	mm ²	mm ²	mm	mm	mm	mm	mm	mm	kg/km	kg/km	kN	Ω/km	MPa	1/K
185-AL1/43-ST6C	184,7	43,1	227,8	1+6	2,80	2,80	2,80	8,40	19,6	847,7	856,2	91,18	0,1565	80 500	1,79E-05
326-AL1/86-ST6C	325,7	86,0	411,7	1+6+12	3,60	2,40	2,40	12,0	26,4	1 576,1	1 595,0	173,31	0,0889	83 200	1,75E-05

1) Hmotnost vodiče s mazanou dušou, stanovená podle přílohy B EN 50182 pro případ mazání (1).

Směr vinutí vrchní vrstvy všech vodičů pravotočivý (Z).

Hodnoty konečného modulu pružnosti a teplotního součinitele délkové roztažnosti jsou stanoveny výpočtem podle IEC/TR 61597.

Tabulka G.3 Vlastnosti doporučených vodičů pro venkovní vedení s napětím nad 45 kV AC – Typ AL4/ST6C

Označení	Průřez		Počet drátů		Průměr drátů		Průměr		Hmotnost na jednotku délky (bez maziva)	Hmotnost na jednotku délky vč. maziva ¹⁾	Jmenovitá pevnost	Dc odpor	Konečný modul pružnosti	Součinitel délkové roztažnosti	
	AL	ST	Celkový	AL	ST	AL	ST	důše							celkový
	mm ²	mm ²	mm ²	mm	mm	mm	mm	mm	mm	kg/km	kg/km	kN	Ω/km	MPa	1/K
185-AL4/43-ST6C	184,7	43,1	227,8	1+6	2,80	2,80	2,80	8,40	19,6	847,1	855,7	120,81	0,1805	80 500	1,79E-05

1) Hmotnost vodiče s mazanou dušou, stanovená podle přílohy B EN 50182 pro případ mazání (1).

Směr vinutí vrchní vrstvy vodiče pravotočivý (Z).

Hodnoty konečného modulu pružnosti a teplotního součinitele délkové roztažnosti jsou stanoveny výpočtem podle IEC/TR 61597.

Tabulka G.4 Vlastnosti doporučených vodičů pro venkovní vedení s napětím nad 45 kV AC – Typ A20SA

Označení	Průřez		Počet drátů		Průměr		Hmotnost na jednotku délky	Jmenovitá pevnost	Dc odpor		Konečný modul pružnosti	Součinitel délkové roztažnosti
	AL	ST	Drátů	Vodiče	Vypočtený z hliníku i oceli	Vypočtený jen z hliníku						
	mm ²	mm ²	mm	mm	kg/km	kN	Ω/km	Ω/km	MPa	1/K		
66-A20SA	65,8	1+6+12	2,10	10,5	441,0	88,18	1,3102	1,7412	159 000	1,30E-05		
93-A20SA	93,3	1+6+12	2,50	12,5	624,9	124,98	0,9245	1,2286	159 000	1,30E-05		

Směr vinutí vrchní vrstvy všech vodičů pravotočivý (Z).

Hodnoty konečného modulu pružnosti a teplotního součinitele délkové roztažnosti jsou převzaty z tabulky F.21 EN 50182:2001.

Tabulka G.5 - Vlastnosti používaných vodičů pro venkovní vedení s napětím do 45 kV AC

Označení	Průřez		Počet drátů		Průměr drátů		Průměr		Hmotnost (bez maziva)	Jmenovitá pevnost	Konečný modul pružnosti	Součinitel délkové roztlačnosti	Jmenovitý DC odpor	Jmenovitý DC odpor s ST duší
	AL	ST	AL	ST	AL	ST	duše	celkový						
podle EN 50182	[mm ²]	[mm ²]	[mm]	[mm]	[mm]	[mm]	[mm]	[mm]	[kg/km]	[kN]	[Mpa]	[1/K]	[Ω/km]	[Ω/km]
původní														
24-AL1/4-ST1A	23,64	3,94	2,24	2,24	2,24	2,24	2,24	6,72	95,46	8,87	79 000*	1,86E-05	1,2120	1,1828
37-AL1/6-ST1A	36,94	6,16	2,80	2,80	2,80	2,80	2,80	8,40	149,2	13,30	79 000*	1,86E-05	0,7757	0,7569
47-AL1/8-ST1A	46,76	7,79	3,15	3,15	3,15	3,15	3,15	9,45	188,8	16,29	79 000*	1,86E-05	0,6129	0,5980
66-AL1/11-ST1A	66,16	10,78	1,80	1,40	1,40	1,40	4,20	11,40	267,0	24,85	74 200*	1,89E-05	0,4365	0,4261
92-AL1/16-ST1A	91,78	15,89	2,12	1,70	1,70	1,70	5,10	13,58	377,7	35,11	74 200*	1,87E-05	0,3147	0,3067
128-AL1/22-ST1A	127,63	21,99	2,50	2,00	2,00	2,00	6,00	16,00	524,5	48,06	74 200*	1,87E-05	0,2263	0,2206

Směr vinutí vrchní vrstvy všech vodičů pravotočivý (Z).

Hodnoty konečného modulu pružnosti, označené *, jsou typické hodnoty podle IEC/TR 61597 pro danou konstrukci.

Hodnoty teplotního součinitele délkové roztlačnosti jsou stanoveny výpočtem podle IEC/TR 61597.

Poznámka: Tabulka obsahuje parametry vodičů vyráběných podle dřívější ČSN 02 4210 s vlastnostmi stanovenými podle ČSN EN 50 182 : 2002





Tabulka G.6 - Vlastnosti používaných vodičů pro venkovní vedení s napětím do 45 kV AC

Označení podle EN 50182	původní		Průřez		Počet drátů		Průměr drátů		Průměr		Hmotnost (bez maziva)	Jmenovitá pevnost	Konečný modul pružnosti	Součinitel délkové roztlačnosti	Jmenovitý DC odpor	Jmenovitý DC odpor s ST dušič		
	AL	ST	AL	ST	AL	ST	AL	ST	duše	celkový							[mm ²]	[mm ²]
24-AL1/4-ST1A	23,64	3,94	27,58	6	1	2,24	2,24	2,24	2,24	2,24	6,72	8,87	79 000*	1,86E-05	1,2120	1,1823		
42-AL1/7-ST1A	42,41	7,07	49,48	6	1	3,0	3,00	3,00	3,00	3,00	9,00	15,27	79 000*	1,86E-05	0,6757	0,6593		
42-AL1/25-ST1A	42,36	24,71	67,07	12	1+6	2,12	2,12	2,12	2,12	6,36	10,60	36,53	104 700	1,53E-05	0,6817	0,6270		
72-AL1/11-ST1A	71,68	10,78	82,45	9+15	1+6	1,95	1,40	1,40	4,20	4,20	12,00	25,87	72 600	1,91E-05	0,4028	0,3938		
66-AL1/11-ST1A	66,27	10,78	77,04	6	1+6	3,75	1,40	1,40	4,20	11,70	266,2	23,21	73 900	1,89E-05	0,4332	0,4227		
100-AL1/25-ST1A	99,99	24,71	124,70	12+18	1+6	2,06	2,12	2,12	6,36	14,60	469,6	46,91	81 800	1,77E-05	0,2891	0,2822		
110-AL1/22-ST1A	110,34	21,99	132,33	11+17	1+6	2,24	2,00	2,00	6,00	14,96	476,9	45,59	77 400	1,83E-05	0,2618	0,2560		
143-AL1/25-ST1A	143,40	24,71	168,11	10+16	1+6	2,65	2,12	2,12	6,36	16,96	589,3	53,29	74 200*	1,87E-05	0,2014	0,1969		

Směr vinutí vrchní vrstvy všech vodičů pravotočivý (Z).

Hodnoty konečného modulu pružnosti, označené *, jsou typické hodnoty podle IEC/TR 61597 pro danou konstrukci.

Ostatní hodnoty modulu pružnosti a teplotního součinitele délkové roztlačnosti jsou stanoveny výpočtem podle IEC/TR 61597.

Poznámka: Tabulka obsahuje parametry vodičů vyráběných podle dřívější PN ZSNP s vlastnostmi stanovenými podle ČSN EN 50 182 : 2002

Characteristics of aluminium
conductors steel reinforced used
in Germany – Type AL1/ST1A

EN 50182
Table F.19



Code	Areas		No. of wires		Diameter		Diameter		Mass per unitlength kg/km	Rated strength kN	DC resistance Ω/km	Final modulus of elasticity N/mm ²	Coefficient of linear expansion 1/K	Current carrying capacity A
	AL mm ²	ST mm ²	Total mm ²	AL	ST	AL	ST	Core						
15-AL1/3-ST1A	15,3	2,54	17,8	6	1,80	1,80	1,80	1,80	61,6	5,80	1,8769	81 000	1,92E-05	105
24-AL1/4-ST1A	23,9	3,98	27,8	6	2,25	2,25	2,25	2,25	96,3	8,95	1,2012	81 000	1,92E-05	140
34-AL1/6-ST1A	34,4	5,73	40,1	6	2,70	2,70	2,70	2,70	138,7	12,37	0,8342	81 000	1,92E-05	170
44-AL1/32-ST1A	44,0	31,7	75,6	14	2,00	2,40	2,40	7,20	369,3	44,24	0,6574	110 000	1,50E-05	-
48-AL1/8-ST1A	48,3	8,04	56,3	6	3,20	3,20	3,20	3,20	194,8	16,81	0,5939	81 000	1,92E-05	210
51-AL1/30-ST1A	51,2	29,8	81,0	12	2,33	2,33	2,33	6,99	374,7	42,98	0,5644	107 000	1,53E-05	-
70-AL1/11-ST1A	69,9	11,4	81,3	10+16	1,85	1,44	1,44	4,32	282,2	26,27	0,4132	77 000	1,89E-05	290
94-AL1/15-ST1A	94,4	15,3	109,7	10+16	2,15	1,67	1,67	5,01	380,6	34,93	0,3060	77 000	1,89E-05	350
97-AL1/56-ST1A	96,5	56,3	152,8	12	3,20	3,20	3,20	9,60	706,8	77,85	0,2992	107 000	1,53E-05	-
106-AL1/76-ST1A	105,7	75,5	181,2	14	3,10	2,25	2,25	11,3	885,3	105,82	0,2742	110 000	1,50E-05	-
122-AL1/20-ST1A	121,6	19,8	141,4	10+16	2,44	1,90	1,90	5,70	491,0	44,50	0,2376	77 000	1,89E-05	410
122-AL1/71-ST1A	122,1	71,3	193,4	12	3,60	3,60	3,60	10,8	894,5	97,92	0,2364	107 000	1,53E-05	-
128-AL1/30-ST1A	127,9	29,8	157,8	12+18	2,33	2,33	2,33	6,99	587,0	56,41	0,2260	82 000	1,78E-05	425
149-AL1/24-ST1A	148,9	24,2	173,1	10+16	2,70	2,10	2,10	6,30	600,8	53,67	0,1940	77 000	1,89E-05	470
184-AL1/30-ST1A	183,8	29,8	213,6	10+16	3,00	2,33	2,33	6,99	741,0	65,27	0,1571	77 000	1,89E-05	535
212-AL1/49-ST1A	212,1	49,5	261,5	12+18	3,00	3,00	3,00	9,00	973,1	92,46	0,1363	82 000	1,78E-05	610
231-AL1/30-ST1A	230,9	29,8	260,8	24	3,50	2,33	2,33	6,99	870,9	72,13	0,1250	74 000	1,96E-05	630
243-AL1/39-ST1A	243,1	39,5	282,5	10+16	3,45	2,68	2,68	8,04	980,1	85,12	0,1188	77 000	1,89E-05	645
264-AL1/34-ST1A	263,7	34,1	297,7	24	3,74	2,49	2,49	7,47	994,4	81,04	0,1095	74 000	1,96E-05	680
304-AL1/49-ST1A	304,3	49,5	353,7	10+16	3,86	3,00	3,00	9,00	1 227,3	105,09	0,0949	77 000	1,89E-05	740
305-AL1/39-ST1A	304,6	39,5	344,1	12+18+24	2,68	2,68	2,68	8,04	1 151,2	96,80	0,0949	70 000	1,93E-05	740
339-AL1/30-ST1A	339,3	29,8	369,1	48	3,00	2,33	2,33	6,99	1 171,2	91,71	0,0852	62 000	2,05E-05	790
382-AL1/49-ST1A	381,7	49,5	431,2	12+18+24	3,00	3,00	3,00	9,00	1 442,5	121,30	0,0758	70 000	1,93E-05	840
434-AL1/56-ST1A	434,3	56,3	490,6	12+18+24	3,20	3,20	3,20	9,60	1 641,3	133,59	0,0666	70 000	1,93E-05	900
449-AL1/39-ST1A	448,7	39,5	488,2	48	3,45	2,68	2,68	8,04	1 549,1	119,05	0,0644	62 000	2,05E-05	920
490-AL1/64-ST1A	490,3	63,6	553,8	12+18+24	3,40	3,40	3,40	10,2	1 852,9	150,81	0,0590	70 000	1,93E-05	960
550-AL1/71-ST1A	549,7	71,3	620,9	12+18+24	3,60	3,60	3,60	10,8	2 077,2	166,32	0,0526	70 000	1,93E-05	1 020
562-AL1/49-ST1A	561,7	49,5	611,2	48	3,86	3,00	3,00	9,00	1 939,5	146,28	0,0515	62 000	2,05E-05	1 040
653-AL1/45-ST1A	653,5	45,3	698,8	45	4,30	2,87	2,87	8,61	2 159,9	156,18	0,0442	61 000	2,09E-05	1 120
679-AL1/86-ST1A	678,6	86,0	764,5	12+18+24	4,00	2,40	2,40	12,0	2 549,7	206,56	0,0426	68 000	1,94E-05	1 150

NOTE 1 Direction of lay of external layer is righthand (Z).
 NOTE 2 Values of final modulus of elasticity and coefficient of linear expansion for the conductor sizes listed in the Table used in Germany. Values for other conductor constructions may be Calculated usány the Metod given in IEC 61597.
 NOTE 3 Guedline values of current carrying capacity are valid up to a frequency of 60 Hz, assuming a wind velocity of 0.6 m/s, the effect of solar radiation for Germany, an initial ambient temperature of 35 °C and a conductor temperature of 80 °C. For special applications, when there is no air turbulence, the values should be reduced by 30%.



Code	Areas		No. of wires		Diameter		Diameter		Mass per unit length kg/km	Rated strength kN	DC resistance Ω /km	Final modulus of elasticity N/mm ²	Coefficient of linear expansion 1/K	Current carrying capacity A
	AL	ST	Total	AL		ST								
	mm ²	mm ²	mm ²	mm	mm	mm	mm							
34-AL1/6-ST1A	34,4	5,73	40,1	6	1	2,70	2,70	2,70	138,7	12,37	0,8342	81 000	1,92E-05	180
48-AL1/8-ST1A	48,3	8,04	56,3	6	1	3,20	3,20	3,20	194,8	16,81	0,5939	81 000	1,92E-05	220
70-AL1/11-ST1A	69,9	11,4	81,3	10+16	1+6	1,85	1,44	4,32	282,2	26,27	0,4132	77 000	1,89E-05	290
94-AL1/22-ST1A	94,2	22,0	116,2	12+18	1+6	2,00	2,00	6,00	432,5	43,17	0,3067	82 000	1,92E-05	350
94-AL1/15-ST1A	94,4	15,3	109,7	10+16	1+6	2,15	1,67	5,01	380,6	34,93	0,3060	77 000	1,89E-05	350
97-AL1/34-ST1A	96,8	34,4	131,1	36	1+6	1,85	2,50	7,50	536,5	57,05	0,2990	90 000	1,92E-05	360
122-AL1/20-ST1A	121,6	19,8	141,4	10+16	1+6	2,44	1,90	5,70	491,0	44,50	0,2376	77 000	1,92E-05	410
119-AL1/42-ST1A	118,8	41,6	160,4	36	1+6	2,05	2,75	8,25	653,9	68,79	0,2435	90 000	1,92E-05	415
128-AL1/30-ST1A	127,9	29,8	157,8	12+18	1+6	2,33	2,33	6,99	587,0	56,41	0,2260	82 000	1,92E-05	425
149-AL1/24-ST1A	148,9	24,2	173,1	10+16	1+6	2,70	2,10	6,30	600,8	53,67	0,1940	77 000	1,92E-05	470
150-AL1/53-ST1A	149,6	52,8	202,4	36	1+6	2,30	3,10	9,30	827,1	84,29	0,1934	90 000	1,92E-05	480
172-AL1/40-ST1A	171,8	40,1	211,8	12+18	1+6	2,70	2,70	8,10	788,2	74,89	0,1683	82 000	1,92E-05	515
184-AL1/30-ST1A	183,8	29,8	213,6	10+16	1+6	3,00	2,33	6,99	741,0	65,27	0,1571	77 000	1,92E-05	535
209-AL1/34-ST1A	209,1	34,1	243,2	10+16	1+6	3,20	2,49	7,47	844,1	73,36	0,1381	77 000	1,92E-05	590
212-AL1/49-ST1A	212,1	49,5	261,5	12+18	1+6	3,00	3,00	9,00	973,1	92,46	0,1363	82 000	1,92E-05	610
243-AL1/39-ST1A	243,1	39,5	282,5	10+16	1+6	3,45	2,68	8,04	980,1	85,12	0,1188	77 000	1,92E-05	640
238-AL1/82-ST1A	237,8	82,4	320,2	36	19	2,90	2,35	11,8	1 305,3	134,37	0,1218	99 890	1,92E-05	645
257-AL1/60-ST1A	256,6	59,9	316,5	12+18	1+6	3,30	3,30	9,90	1 177,5	108,20	0,1126	82 000	1,92E-05	665
304-AL1/49-ST1A	304,3	49,5	353,7	10+16	1+6	3,86	3,00	9,00	1 227,3	105,09	0,0949	77 000	1,92E-05	740
341-AL1/109-ST1A	341,2	108,8	450,0	78	19	2,36	2,70	13,5	1 797,4	183,73	0,0848	84 000	1,92E-05	800
382-AL1/49-ST1A	381,7	49,5	431,2	12+18+24	1+6	3,00	3,00	9,00	1 442,5	121,30	0,0758	70 000	1,92E-05	840
449-AL1/39-ST1A	448,7	39,5	488,2	48	1+6	3,45	2,68	8,04	1 549,1	119,05	0,0644	62 000	1,92E-05	920
562-AL1/49-ST1A	561,7	49,5	611,2	48	1+6	3,86	3,00	9,00	1 939,5	146,28	0,0515	62 000	1,92E-05	1 040
635-AL1/117-ST1A	634,7	117,0	751,7	38+22	19	3,25 4,30	2,80	14,0	2 671,2	236,5	0,0455	84 120	1,92E-05	1 106
679-AL1/86-ST1A	678,6	86,0	764,5	12+18+24	1+6+12	4,00	2,40	12,0	2 549,7	206,56	0,0426	68 000	1,92E-05	1 150

NOTE 1 Direction of lay of external layer is right-hand (Z).

NOTE 2 Values of final modulus of elasticity and coefficient of linear expansion for the conductor sizes listed in the Table used in Austria.

Values for other conductor constructions may be calculated using the Method given in IEC 61597.

NOTE 3 Guideline values of current carrying capacity are valid up to a frequency of 60 Hz, assuming a wind velocity of 0,6 m/s, the effect of solar radiation for Germany, an initial ambient temperature of 35 °C and a conductor temperature of 80 °C. For special applications, when there is no air turbulence, the values should be reduced by 30%.

Characteristics of aluminium
conductors steel reinforced used
in the United Kingdom – Type AL1/ST1A

EN 50182
Table F.42

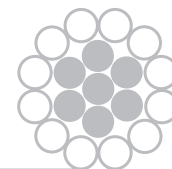

Code	Old Code	Areas		No. of wires		Diameter			Diameter		Mass per unitlength kg/km	Rated strength kN	DC resistance Ω /km
		AL mm ²	ST mm ²	AL	ST	AL	ST	Core mm	Cond. mm				
										Total mm ²			
11-AL1/2-ST1A	MOLE	10,6	1,77	12,4	6	1	1,50	1,50	1,50	4,50	42,8	4,14	2,7027
21-AL1/3-ST1A	SQUIREL	21,0	3,50	24,5	6	1	2,11	2,11	2,11	6,33	84,7	7,87	1,3659
26-AL1/4-ST1A	GOPHER	26,2	4,37	30,6	6	1	2,36	2,36	2,36	7,08	106,0	9,58	1,0919
32-AL1/5-ST1A	WEASEL	31,6	5,27	36,9	6	1	2,59	2,59	2,59	7,77	127,6	11,38	0,9065
42-AL1/7-ST1A	FERRET	42,4	7,07	49,5	6	1	3,0	3,0	3,0	9,0	171,2	15,27	0,6757
53-AL1/9-ST1A	RABBIT	52,9	8,81	61,7	6	1	3,35	3,35	3,35	10,1	213,5	18,42	0,5419
73-AL1/13-ST1A	HORSE	73,4	12,8	86,2	12	7	2,79	2,79	2,79	8,37	537,3	61,26	0,3936
79-AL1/13-ST1A	RACCOON	78,8	13,1	91,9	6	1	4,09	4,09	4,09	12,3	318,3	27,6	0,3635
95-AL1/16-ST1A	CAT	95,4	15,9	111,3	6	1	4,50	4,50	4,50	13,5	385,3	32,76	0,3003
105-AL1/14-ST1A	DOG	105,0	13,6	118,5	6	7	4,72	1,57	1,57	14,2	394,0	32,65	0,2733
132-AL1/20-ST1A	COYOTE	131,7	20,1	151,8	26	7	2,54	1,91	1,91	15,9	520,7	45,86	0,2192
159-AL1/9-ST1A	DINGO	158,7	8,81	167,5	18	1	3,35	3,35	3,35	16,8	505,2	35,87	0,1814
158-AL1/37-ST1A	WOLF	158,1	36,9	194,9	30	7	2,59	2,59	2,59	18,1	725,3	68,91	0,1829
183-AL1/43-ST1A	LYNX	183,4	42,8	226,2	30	7	2,79	2,79	2,79	19,5	841,6	79,97	0,1576
184-AL1/10-ST1A	CARACAL	184,2	10,2	194,5	18	1	3,61	3,61	3,61	18,1	586,7	40,74	0,1562
212-AL1/49-ST1A	PANTHER	212,1	49,5	261,5	30	7	3,00	3,00	3,00	21,0	973,1	92,46	0,1363
211-AL1/12-ST1A	JAGUAR	210,6	11,7	222,3	18	1	3,86	3,86	3,86	19,3	670,8	46,57	0,1366
238-AL1/56-ST1A	LION	238,3	55,6	293,9	30	7	3,18	3,18	3,18	22,3	1 093,4	100,47	0,1213
264-AL1/62-ST1A	BEAR	264,4	61,7	326,1	30	7	3,35	3,35	3,35	10,1	213,4	111,50	0,1093
324-AL1/76-ST1A	GOAT	324,3	75,7	400,0	30	7	3,71	3,71	3,71	11,1	26,0	135,13	0,0891
375-AL1/88-ST1A	SHEEP	375,1	87,5	462,6	30	7	3,99	3,99	3,99	12,0	27,9	156,30	0,0771
374-AL1/48-ST1A	ANTELOPE	374,1	48,5	422,6	54	7	2,97	2,97	2,97	8,91	26,7	118,88	0,0773
430-AL1/100-ST1A	DEER	429,6	100,2	529,8	30	7	4,27	4,27	4,27	12,8	29,9	179,00	0,0673
429-AL1/56-ST1A	ZEBRA	428,9	55,6	484,5	54	7	3,18	3,18	3,18	9,54	28,6	131,92	0,0674
476-AL1/62-ST1A	CAMEL	476,0	61,7	537,7	54	7	3,35	3,35	3,35	10,1	30,2	146,40	0,0608
528-AL1/69-ST1A	MOOSE	528,5	68,5	597,0	54	7	3,53	3,53	3,53	10,6	31,8	159,92	0,0547

NOTE Direction of lay of external layer is right-hand (Z).

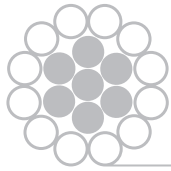

Označenie Code word Bezeichnung	Konštrukcia Construction Aufbau		Priemer Overall diameter Durchmesser	Prierez Cross section Querschnitt			Hmotnosť Weight Gewicht	Matematická únosnosť Calculated breaking load Rechnerische Bruchkraft	Vypočítaný odpor pri 20 °C Calculated resistance at 20 °C Rechnerische Widerstand bei 20 °C	
	Al Aluminium Aluminium	Fe Steel Stahl	Lana Conductor Seile	Lana Conductor Seile	Al Aluminium Aluminium	Fe Steel Stahl				
mm ² mm ² mm ²	počet/Ø mm No./Ø mm Anzahl/Ø mm		mm mm mm	mm ² mm ² mm ²			kg/km kg/km kg/km	kN kN kN	Ω/km Ω/km Ω/km	
AFL-20	670	42/4.5	7/2.5	34.50	702.40	668.0	34.36	2116	140.3	0.0438
	775	42/4.85	7/2.7	37.20	816.00	775.9	40.08	2458	163.16	0.0377
	840	42/5.05	7/2.8	38.70	884.30	841.2	43.1	2662	176.49	0.0348
AFL-8	350	54/2.9	7/2.9	26.10	402.90	356.7	46.2	1352	110.32	0.0821
	400	54/3.1	7/3.1	27.90	460.40	407.6	52.8	1546	124.57	0.0718
	525	54/3.5	7/3.5	31.50	586.90	519.5	67.4	1970	158.28	0.0564
	675	54/4.0	19/2.4	36.00	764.55	678.6	85.9	2558	203.96	0.0431
AFL-6	16	6/1.8	1/1.8	5.40	17.81	15.27	2.54	62	5.67	1.9170
	25	6/2.25	1/2.25	6.75	27.84	23.86	3.98	97	8.67	1.2270
	35	6/2.7	1/2.7	8.10	40.08	34.35	5.73	140	12.19	0.8522
	50	6/3.2	1/3.2	9.60	56.29	48.25	8.04	196	16.8	0.6063
	70	6/3.75	1/3.75	11.25	77.31	66.27	11.04	269	23.01	0.4414
	95	26/2.1	7/1.65	13.35	105.00	90.05	14.97	368	32.63	0.3251
	120	26/2.45	7/1.95	15.65	143.50	122.6	20.91	505	44.54	0.2388
	150	26/2.7	7/2.15	17.25	174.30	148.9	25.41	614	53.54	0.1966
	185	26/3.0	7/2.40	19.20	215.50	183.8	31.67	759	65.71	0.1593
	240	26/3.4	7/2.70	21.70	276.20	236.1	40.08	971	82.8	0.1240
	300	26/3.8	7/3.0	24.20	344.40	294.9	49.48	1208	102.17	0.0993
AFL-4	50	30/1.6	7/1.6	11.2	74.339	60.32	14.07	279	26.9	0.4853
	70	30/1.8	7/1.8	12.6	94.15	76.34	17.81	353	33.83	0.3835
	95	30/2.0	7/2.0	14	116.24	94.25	21.99	436	41.78	0.3106
	120	30/2.25	7/2.25	15.75	147.13	119.3	27.83	552	52.41	0.2453
	150	30/2.25	7/2.55	17.85	189	153.2	35.75	708	66.11	0.1911
	185	30/2.8	7/2.8	19.6	227.8	184.7	43.1	854	78.98	0.1585
	240	30/3.2	19/1.95	22.55	298	241.3	56.74	1119	102.97	0.1213
	300	30/3.6	19/2.15	25.15	374.4	305.4	68.98	1393	216.77	0.0959
	350	30/3.85	19/2.3	26.9	428.1	349.2	78.94	1594	144.33	0.0838
	540	30/4.8	19/3.0	34.2	677.2	542.9	134.3	2571	236.08	0.0539
AFL-3	16	8/1.6	1/2.655	5.85	21.6	16.08	5.52	88	9.21	1.8210
	25	8/2.0	1/3.35	7.35	33.94	25.13	8.81	139	14.52	1.1650
	35	8/2.25	1/3.75	8.25	42.85	31.81	11.04	174	18.13	0.9203
AFL-1.7	38	12/2.0	7/2.0	10	59.69	37.7	21.99	280	31.85	0.7765
	50	12/2.25	7/2.25	11.25	75.54	47.71	27.83	354	40.12	0.6136
	70	12/2.55	7/2.555	12.75	97.03	61.28	35.75	455	51.05	0.4777
	95	12/3.0	7/3.0	15	134.3	84.82	49.48	630	70.33	0.3451
AFL-1.25	120	155/3.2	19/2.555	19.15	217.6	120.6	97.03	1109	130.26	0.2427
	185	15/3.75	19/3.0	22.5	300	165.7	134.3	1531	179.933	0.1767
	240	15/4.5	19/3.6	27	432	238.6	193.4	2206	257.93	0.1227
AFL-1.25	35	16/1.75	7/2.4	10.7	70.15	38.48	31.67	365	43.2	0.7610



Označenie Code word Bezeichnung	Konštrukcia Construction Aufbau		Priemer Overall diameter Durchmesser		Prierez Cross section Querschnitt		Hmotnosť Weight Gewicht	Matematická únosnosť Calculated breaking load Rechnerische Bruchkraft	Vypočítaný odpor pri 20 °C Calculated resistance at 20 °C Rechnerische Widerstand bei 20 °C
	Al Aluminium Aluminium	Fe Steel Stahl	Lana Conductor Seile	Fe Steel Stahl	Al Aluminium Aluminium	Fe Steel Stahl			
mm ² mm ² mm ²	počet/Ø mm No./Ø mm Anzahl/Ø mm		mm mm mm		mm ² mm ² mm ²		kg/km kg/km kg/km	N N N	Ω/km Ω/km Ω/km
16/2.5	6/1.8	1/1.8	5.40	1.8	15.26	2.54	65	5920	1.8600
25/4.0	6/2.25	1/2.25	6.75	2.25	23.85	3.97	98	9000	1.9200
35/6	6/2.7	1/2.70	8.10	2.7	34.35	5.72	140	12680	0.8529
50/8	6/3.2	1/3.20	9.60	3.2	48.25	8.04	196	17480	0.588
70/12	26/1.85	7/1.44	11.72	4.32	69.89	11.4	288	27700	0.4204
95/15	26/2.15	7/1.67	13.61	5.01	94.37	15.33	386	35750	0.3115
120/20	26/2.45	7/1.90	15.50	5.7	122.5	19.85	501	45850	0.2399
150/25	26/2.70	7/2.10	17.10	6.3	148.8	24.24	608	55250	0.1975
185/30	26/3.0	7/2.33	18.99	6.99	183.7	29.85	751	66200	0.1600
240/40	26/3.45	7/2.68	21.84	8.04	243	38.59	983	85340	0.1209
250/40	26/3.50	7/2.80	22.40	8.4	250.1	43.1	1040	84000	0.1172
300/50	26/3.86	7/3.00	24.40	9	304.2	49.48	1240	106980	0.0966
300/40	54/2.68	7/2.68	24.12	8.04	297.7	38.59	1168	98670	0.0967
400/53	54/3.10	7/3.10	27.90	9.3	407.5	52.83	1568	131300	0.0724
500/66	54/3.45	7/3.45	31.05	10.35	504.7	65.44	1935	157500	0.0584
625/82	54/3.84	7/3.84	34.56	11.52	625.2	81.07	2400	192700	0.0472
95/56	12/3.20	7/3.20	16.00	9.6	96.51	56.3	712	81550	0.3039
120/70	12/3.60	7/3.60	18.00	10.8	122.2	71.25	901	199950	0.2402
150/85	12/3.92	7/3.92	19.60	11.76	144.8	84.48	1070	118100	0.2025



Hliníkové jadrá káblov–sektorové

All Aluminium conductors-sectional

Aluminium Sektorseile

Hliníkové jadrá káblov–sektorové podľa normy EN 60228.

The All Aluminium conductors-sectional in accordance EN 60228.

Die sektorförmigen Aluminiumseile nach der Norm EN 60228.

Označenie Code word Bezeichnung	Menovitý prierez Nominal cross section Nennquerschnitt	Uhol Angle Winkel	Hmotnosť Weight Gewicht	Maximálny odpor Maximal resistance Maximal Widerstand	Konštrukcia Construction Aufbau
	mm ² mm ² mm ²	° ° °	kg/km kg/km kg/km	Ω/km Ω/km Ω/km	mm x počet mm x No. of wires mm x Anzahl
Lano Al 50 SM72	50	72	124,0	0,641	2,19 x 13
Lano Al 50 SM90	50	90	124,0	0,641	2,19 x 13
Lano Al 50 SM120	50	120	124,0	0,641	2,19 x 13
Lano Al 70 SM55	70	55	179,4	0,443	2,19 x 19
Lano Al 70 SM64	70	64	179,4	0,443	2,19 x 19
Lano Al 70 SM72	70	72	179,4	0,443	2,19 x 19
Lano Al 70 SM90	70	90	179,4	0,443	2,19 x 19
Lano Al 70 SM120	70	120	179,4	0,443	2,19 x 19
Lano Al 95 SM58	95	58	248,3	0,320	2,57 x 19
Lano Al 95 SM72	95	72	248,3	0,320	2,57 x 19
Lano Al 95 SM90	95	90	248,3	0,320	2,57 x 19
Lano Al 95 SM120	95	120	248,3	0,320	2,57 x 19
Lano Al 120 SM55	120	55	314,0	0,253	2,57 x 24
Lano Al 120 SM72	120	72	314,0	0,253	2,57 x 24
Lano Al 120 SM90	120	90	314,0	0,253	2,57 x 24
Lano Al 120 SM98	120	98	314,0	0,253	2,57 x 24
Lano Al 120 SM120	120	120	314,0	0,253	2,57 x 24
Lano Al 150 SM90	150	90	385,8	0,206	2,38 x 37
Lano Al 150 SM101	150	101	385,8	0,206	2,38 x 37
Lano Al 150 SM120	150	120	385,8	0,206	2,38 x 37
Lano Al 185 SM90	185	90	484,5	0,164	2,57 x 37
Lano Al 185 SM100	185	100	484,5	0,164	2,57 x 38
Lano Al 185 SM120	185	120	484,5	0,164	2,57 x 39
Lano Al 240 SM90	240	90	635,6	0,125	2,57 x 48
Lano Al 240 SM101	240	101	635,6	0,125	2,57 x 48
Lano Al 240 SM120	240	120	635,6	0,125	2,57 x 48

Hliníkové jadrá káblov-komprimované

All Aluminium conductors-compressed

Aluminium Seile – Komprimierte



Hliníkové jadrá káblov-komprimované podľa normy EN 60228.

The All Aluminium conductors-compressed in accordance EN 60228.

Die komprimierten Aluminiumseile nach der Norm EN 60228 entsprechen.

Označenie Code word Bezeichnung	Menovitý prierez Nominal cross section Nennquerschnitt	Priemer Overall diameter Durchmesser	Hmotnosť Weight Gewicht	Maximálny odpor Maximal resistance Maximal Widerstand	Konštrukcia Construction Aufbau
	mm ² mm ² mm ²	mm mm mm	kg/km kg/km kg/km	Ω/km Ω/km Ω/km	mm x počet mm x No. of wires mm x Anzahl
Lano Al 35 RMV	35	7,2	92,1	0,868	2,6 x (1+6)
Lano Al 50 RMV	50	8,3	130,0	0,641	3,05 x (1+6)
Lano Al 70 RMV	70	9,8	181,4	0,443	2,21 x (1+6+12)
Lano Al 95 RMV	95	11,3	251,7	0,320	2,58 x (1+6+12)
Lano Al 120 RMV	120	12,8	319,3	0,253	2,92 x (1+6+12)
Lano Al 150 RMV	150	14,2	380,5	0,206	3,15 x (1+6+12)
Lano Al 185 RMV	185	15,8	489,6	0,164	2,62 x (1+6+12+17)
Lano Al 240 RMV	240	18,1	644,6	0,125	3,00 x (1+6+12+18)
Lano Al 300 RMV	300	20,2	795,0	0,100	3,34 x (1+6+12+18)
Lano Al 400 RMV	400	23,3	1 069,2	0,078	3,00 x (1+6+12+17+22)
Lano Al 500 RMV	500	26,5	1 375,3	0,061	3,43 x (1+6+12+16+22)
Lano Al 630 RMV	630	29,9	1 756,9	0,047	3,84 x (1+6+12+17+22)
Lano Al 240 RMV EDF	240	18,1	696,0	0,124	3,05 x 19 + 2,92 x 18



Code	Old code	Area mm ²	No. of wires	Diameter		Mass per unit length kg/km	Rated strength kN	DC resistance n/km	Final modulus of elasticity N/mm ²	Coefficient of linear expansion 1/K	Current carrying capacity A
				Wire mm	Cond. mm						
16-AL1	16	15,9	7	1,70	5,10	43,4	3,02	1,798 6	60 000	2.30E-05	110
24-AL1	25	24,2	7	2,10	6,30	66,3	4,36	1,178 7	60 000	2.30E-05	145
34-AL1	35	34,4	7	2,50	7,50	93,9	6,01	0,831 7	60 000	2.30E-05	180
49-AL1	50	49,5	7	3,00	9,00	135,2	8,41	0,577 6	60 000	2.30E-05	225
48-AL1	50	48,3	19	1,80	9,00	132,9	8,94	0,594 4	57 000	2.30E-05	225
66-AL1	70	65,8	19	2,10	10,5	180,9	11,85	0,436 7	57 000	2.30E-05	270
93-AL1	95	93,3	19	2,50	12,5	256,3	16,32	0,308 1	57 000	2.30E-05	340
117-AL1	120	117,0	19	2,80	14,0	321,5	19,89	0,245 6	57 000	2.30E-05	390
147-AL1	150	147,1	37	2,25	15,8	405,7	26,48	0,196 0	57 000	2.30E-05	455
182-AL1	185	181,6	37	2,50	17,5	500,9	31,78	0,158 8	57 000	2.30E-05	520
243-AL1	240	242,5	61	2,25	20,3	671,1	43,66	0,119 3	55 000	2.30E-05	625
299-AL1	300	299,4	61	2,50	22,5	828,5	52,40	0,096 6	55 000	2.30E-05	710
400-AL1	400	400,1	61	2,89	26,0	1 107,1	68,02	0,072 3	55 000	2.30E-05	855
500-AL1	500	499,8	61	3,23	29,1	1 382,9	82,47	0,057 9	55 000	2.30E-05	990
626-AL1	625	626,2	91	2,96	32,6	1 739,7	106,45	0,046 4	55 000	2.30E-05	1 140
802-AL1	800	802,1	91	3,35	36,9	2 228,3	132,34	0,036 2	55 000	2.30E-05	1 340
1000-AL1	1000	999,7	91	3,74	41,1	2 777,3	159,95	0,029 1	55 000	2.30E-05	1 540

NOTE 1 Direction of lay of external layer is right-hand (Z).

NOTE 2 Values of final modulus of elasticity and coefficient of linear expansion for the conductor sizes listed in the Table are used in Germany. Values for other conductor constructions may be calculated using the method given in IEC 61597.

NOTE 3 Guideline values of current carrying capacity are valid up to a frequency of 60 Hz, assuming a wind velocity of 0,6 m/s, the effect of solar radiation for Germany, an initial ambient temperature of 35 °C and a conductor temperature of 80 °C. For special applications, when there is no air turbulence, the values should be reduced by 30%.

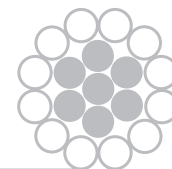

Code	Old code	Area mm ²	No. of wires	Diameter		Mass per unit length kg/km	Rated strength kN	DC Resistance Ω/km
				Wire mm	Cond. mm			
23-AL1	MIDGE	23,3	7	2,06	6,18	63,8	4,20	1,2249
27-AL1	GNAT	26,9	7	2,21	6,63	73,4	4,83	1,0643
37-AL1	MOSQUITO	36,9	7	2,59	7,77	100,8	6,27	0,7749
43-AL1	LADYBIRD	42,8	7	2,79	8,37	117,0	7,28	0,6678
53-AL1	ANT	52,8	7	3,10	9,30	144,4	8,72	0,5409
63-AL1	FLY	63,6	7	3,40	10,2	173,7	10,49	0,4497
74-AL1	BLUEBOTTLE	73,6	7	3,66	11,0	201,3	11,78	0,3880
79-AL1	EARWING	78,6	7	3,78	11,3	214,7	12,57	0,3638
84-AL1	GRASSHOPPER	84,1	7	3,91	11,7	229,7	13,45	0,3400
96-AL1	CLEGG	95,6	7	4,17	12,5	261,3	15,30	0,2989
106-AL1	WASP	106,0	7	4,39	13,2	289,6	16,95	0,2697
106-AL1	BEETLE	106,4	19	2,67	13,4	292,4	18,08	0,2701
132-AL1	BEE	132,0	7	4,90	14,7	360,8	21,12	0,2165
158-AL1	HORNET	157,6	19	3,25	16,3	433,2	26,01	0,1823
186-AL1	CATERPILLAR	185,9	19	3,53	17,7	511,1	29,75	0,1546
213-AL1	CHAFER	213,2	19	3,78	18,9	586,0	34,12	0,1348
238-AL1	SPIDER	237,6	19	3,99	20,0	652,9	38,01	0,1210
266-AL1	COCKROACH	265,7	19	4,22	21,1	730,4	45,52	0,1081
323-AL1	BUTTERFLY	322,7	19	4,65	23,3	886,8	51,63	0,0891
373-AL1	MOTH	373,1	19	5,00	25,0	1 025,3	59,69	0,0770
372-AL1	DRONE	372,4	37	3,58	25,1	1 027,1	59,59	0,0774
415-AL1	CENTIPEDE	415,2	37	3,78	26,5	1 145,1	66,43	0,0695
486-AL1	MAYBUG	486,1	37	4,09	28,6	1 340,6	77,78	0,0593
530-AL1	SCORPION	529,8	37	4,27	29,9	1 461,2	84,77	0,0544
628-AL1	CICADA	628,3	37	4,65	32,6	1 732,9	100,54	0,0459

NOTE Direction of lay of external layer is right-hand (Z).



EN 50182
Table F.18

Vodiče zo zliatiny Al
Characteristics of aluminium alloy
conductors used in Germany – Type AL3

Code	Old code	Area mm ²	No. of wires	Diameter		Mass per unit length kg/km	Rated strength kN	DC resistance Ω/km	Final modulus of elasticity N/mm ²	Coefficient of linear expansion 1/K	Current carrying capacity A
				Wire mm	Cond. mm						
16-AL3	16	15,9	7	1,70	5,10	43,4	4,69	2,0701	60 000	2.30E-05	105
24-AL3	25	24,2	7	2,10	6,30	66,2	7,15	1,3566	60 000	2.30E-05	135
34-AL3	35	34,4	7	2,50	7,50	93,8	10,14	0,9572	60 000	2.30E-05	170
49-AL3	50	49,5	7	3,00	9,00	135,1	14,60	0,6647	60 000	2.30E-05	210
48-AL3	50	48,3	19	1,80	9,00	132,7	14,26	0,6841	57 000	2.30E-05	210
66-AL3	70	65,8	19	2,10	10,5	180,7	19,41	0,5026	57 000	2.30E-05	255
93-AL3	95	93,3	19	2,50	12,5	256,0	27,51	0,3546	57 000	2.30E-05	320
117-AL3	120	117,0	19	2,80	14,0	321,2	34,51	0,2827	57 000	2.30E-05	365
147-AL3	150	147,1	37	2,25	15,8	405,3	43,40	0,2256	57 000	2.30E-05	425
182-AL3	185	181,6	37	2,50	17,5	500,3	53,58	0,1827	57 000	2.30E-05	490
243-AL3	240	242,5	61	2,25	20,3	670,3	71,55	0,1373	55 000	2.30E-05	585
299-AL3	300	299,4	61	2,50	22,5	827,5	88,33	0,1112	55 000	2.30E-05	670
400-AL3	400	400,1	61	2,89	26,0	1 104,9	118,04	0,0832	55 000	2.30E-05	810
500-AL3	500	499,8	61	3,23	29,1	1 381,4	147,45	0,0666	55 000	2.30E-05	930
626-AL3	625	626,2	91	2,96	32,6	1 737,7	184,73	0,0534	55 000	2.30E-05	1075
802-AL3	800	802,1	91	3,35	36,9	2 225,8	236,62	0,0417	55 000	2.30E-05	1255
1000-AL3	1000	999,7	91	3,74	41,1	2 774,3	294,91	0,0334	55 000	2.30E-05	1450

NOTE 1 Direction of lay of external layer is right-hand (Z).

NOTE 2 Values of final modulus of elasticity and coefficient of linear expansion for the conductor sizes listed in the Table are used in Germany.

Values for other conductor constructions may be calculated using the method given in IEC 61597.

NOTE 3 Guideline values of current carrying capacity are valid up to a frequency of 60 Hz, assuming a wind velocity of 0,6 m/s, the effect of solar radiation for Germany, an initial ambient temperature of 35 °C and a conductor temperature of 80 °C. For special applications, when there is no air turbulence, the values should be reduced by 30%.

Vodiče zo zliatiny Al
 Characteristics of aluminium alloy conductors
 used in the United Kingdom - Type AL3

EN 50182
 Table F.40



Code	Old code	Area mm ²	No. of wires	Diameter		Mass per unit length kg/km	Rated strength kN	DC Resistance Ω/km
				Wire mm	Cond. mm			
19-AL3	BOX	18,8	7	1,85	5,55	51,4	5,55	1,7480
24-AL3	ACACIA	23,8	7	2,08	6,24	64,9	7,02	1,3828
30-AL3	ALMOND	30,1	7	2,34	7,02	82,2	8,88	1,0926
35-AL3	CEDAR	35,5	7	2,54	7,62	96,8	10,46	0,9273
42-AL3	DEODAR	42,2	7	2,77	8,31	115,2	12,44	0,7797
48-AL3	FIR	47,8	7	2,95	8,85	130,6	14,11	0,6875
60-AL3	HAZEL	59,9	7	3,30	9,90	163,4	17,66	0,5494
72-AL3	PINE	71,6	7	3,61	10,8	195,6	21,14	0,4591
84-AL3	HOLLY	84,1	7	3,91	11,7	229,5	24,79	0,3913
90-AL3	WILLOW	89,7	7	4,04	12,1	245,0	26,47	0,3665
119-AL3	OAK	118,9	7	4,65	14,0	324,5	35,07	0,2767
151-AL3	MULBERRY	150,9	19	3,18	15,9	414,3	44,52	0,2192
181-AL3	ASH	180,7	19	3,48	17,4	496,1	53,31	0,1830
211-AL3	ELM	211,0	19	3,76	18,8	579,2	62,24	0,1568
239-AL3	POPLAR	239,4	37	2,87	20,1	659,4	70,61	0,1387
303-AL3	SYCAMORE	303,2	37	3,23	22,6	835,2	89,40	0,1095
362-AL3	UPAS	362,1	37	3,53	24,7	997,5	106,82	0,0917
479-AL3	YEW	479,0	37	4,06	28,4	1 319,6	141,31	0,0693
498-AL3	TOTARA	498,1	37	4,14	29,0	1 372,1	146,93	0,0666
587-AL3	RUBUS	586,9	61	3,50	31,5	1 622,0	173,13	0,0567
659-AL3	SORBUS	659,4	61	3,71	33,4	1 822,5	194,53	0,0505
821-AL3	ARAUCHARIA	821,1	61	4,14	37,3	2 269,4	242,24	0,0406
996-AL3	REDWOOD	996,2	61	4,56	41,0	2 753,2	293,88	0,0334

NOTE: Direction of lay of external layer is right-hand (Z).



Kovové bubny
Steel reel
Stahlrommel

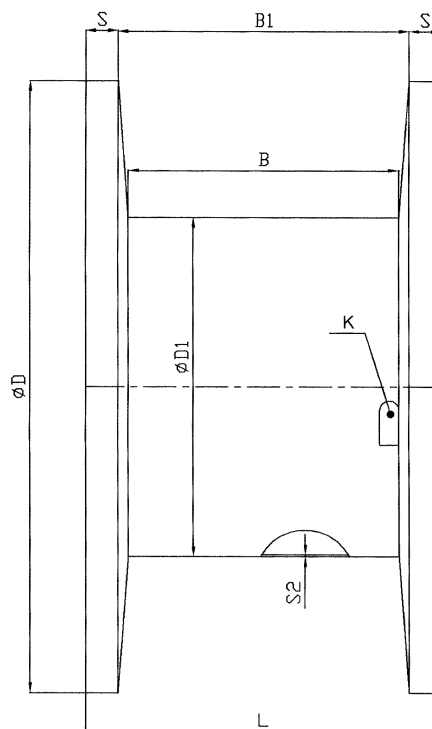
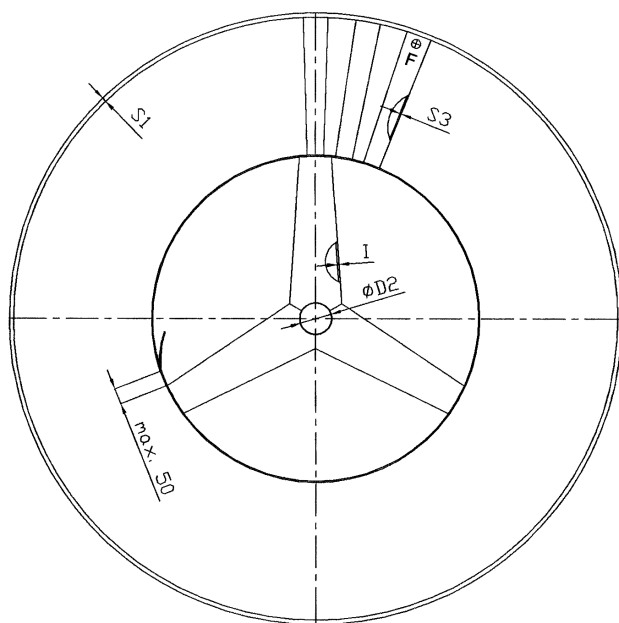

	ØD	ØD ₁	ØD ₂	B	B ₁	L	S	S ₁	S ₂	S ₃	I	K	F	Dovolené zatížení Capacity Zulässige Belastung	Objem Volume Volumen	Hmotnost bubna Reel Mass Trommelgewicht
	mm	mm	mm	mm	mm	mm	mm	mm	mm	mm	mm	mm	mm	kN	m ³	kg
KB Ø1000	1000	600	70	575	595	685	35±5	8	3	1	3	160/60	Ø25/12	8	0.26	56
KB Ø1200	1200	600	70	660	690	770	30±5	10	3	1.5	3	160/60	Ø25/16	12	0.45	82
KB Ø1500	1500	750	92	935	960	1050	45	10	3	1.5	U80	200/100	Ø25/12	25	1.00	160
KB Ø1800	1800	1150	92	895	915	1005	45	10	3	1.5	U80	200/100	Ø25/12	30	1.00	238
KB Ø2000	2000	1200	92	895	915	1026	50	10	3	1.5	U80	200/100	Ø25/12	38	1.20	315
KB Ø2200	2200	1450	92	965	985	1110	60	10	3	1.5	U80	200/100	Ø25/16	50	1.60	352
KB Ø2500	2500	1600	120	1250	1290	1430	70	16	5	2	U120	200/100	Ø25/17	80	2.80	616
KB Ø2800	2800	1800	140	1500	1520	1680	80	15	4	2	5	250/100	Ø25/8	100	3.9	840

Drevené bubny
 Wooden drums
 Holztrommel

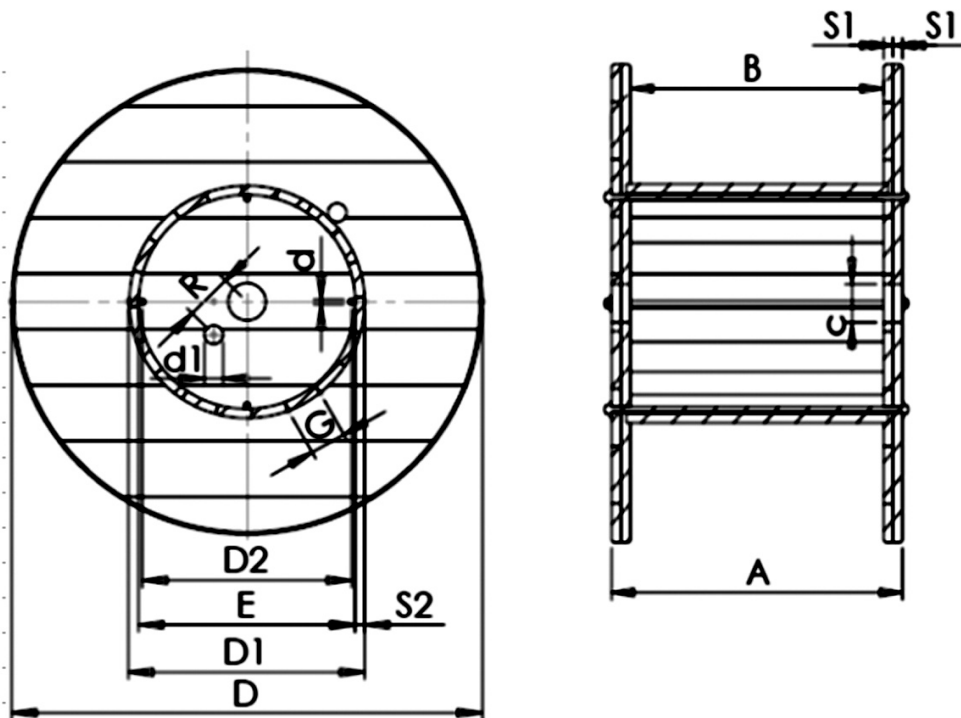

	D	D ₁	B	A	c	E	d ₁	R ±5	G ±2	S ₁	S ₂	d	Počet srutkov No. of Screws Anzahl der schrauben	Nosnosť Load Capacity Belastbar	Hmotnosť bubna Real Mass Trommelgewicht
	mm	mm	mm	mm	mm	mm	mm	mm	mm	mm	mm	mm	ks	kg	kg
10T	1000±20	600±5	590±15	682	85	462	30	150	70	22	22	M10x682	4	1550	75
12T	1200±20	630±15	630±18	722	85	584	30	150	80	23	23	M12x722	4	1800	82
15T	1500±35	1000±15	945±25	1065	100	954	65	300	100	30	30	M16x1065	6	2500	160
18T	1800±35	1000±15	1000±25	1152	128	940	65	300	100	34	34	M16x1152	6	3000	238
20T	2000±35	1250±15	1000±25	1152	128	1182	65	350	100	34	34	M20x1152	6	3800	350
22T	2200±35	1300±15	1000±25	1152	128	1224	65	350	100	34	34	M20x1152	6	5000	452
25T	2500±35	1400±15	990±25	1150	128	1420	65	350	110	40	40	M20x1152	8	7500	616
26T	2600±35	1500±15	1200±25	1372	128	1420	65	350	110	40	46	M20x1380	8	8000	680
24T	2500±35	1400±15	1200±25	1360	128	1420	65	350	110	40	46	M20x1380	8	7500	650

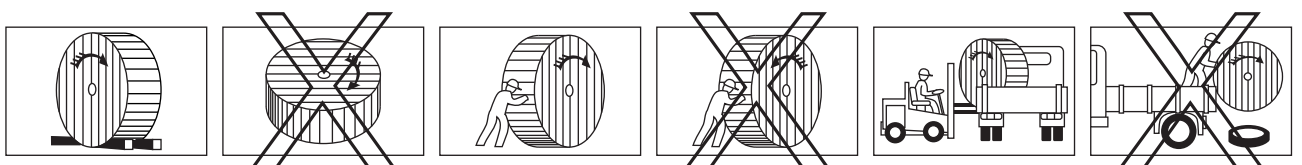



Existujú štyri prípady použitia maziva:

1. prípad: mazaná len oceľová duša (obrázok a))
2. prípad: celý vodič mazaný okrem vonkajšej vrstvy (obrázok b))
3. prípad: celý vodič mazaný vrátane vonkajšej vrstvy (obrázok c))
4. prípad: celý vodič mazaný okrem vonkajšieho povrchu drôtov v vonkajšej vrstve (obrázok d))

Podľa požiadavky zákazníka se môžu špecifikovať aj ďalšie prípady.

a)

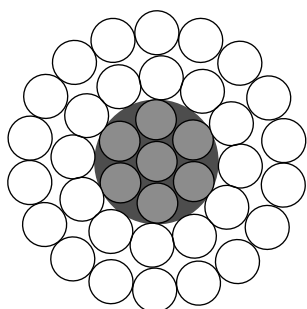

b)

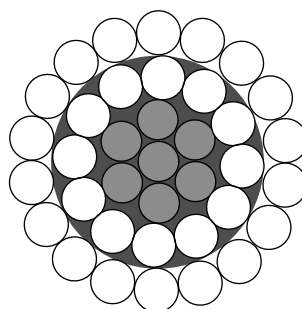

c)

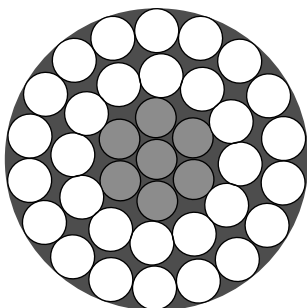

d)

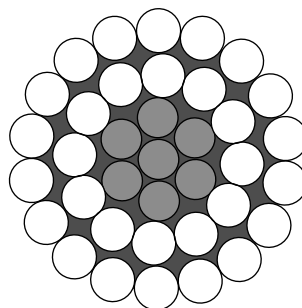

Ťahané rúrky z hliníka

Aluminium drawn tubes



Materiál:	materiál Al 99,5% podľa EN 573-3, AW 1050A
Podľa požiadaviek:	stav mäkký H111 stav tvrdý H14
Povrchová úprava:	bez úpravy - prírodný odtieň (strieborná farba) práškovanie (rôzne farebné odtiene) anodická oxidácia - prírodný odtieň (strieborná farba)
Rozmerový sortiment:	vonkajší priemer od 8 do 60 mm ($\varnothing 6 - 8$ mm po dohode so zákazníkom) hrúbka steny 1 - 11 mm (e: 0,75 - 1 mm po dohode so zákazníkom) maximálna dĺžka ťahaných rúr je 6 000mm
Technické dodacie normy:	EN 754-1
Mechanické vlastnosti:	EN 754-2
Tolerancie:	EN 754-7

Materiálová norma		EN 573-3, AW 1050A Al 99,5%	
Vonkajší priemer		8 - 60 mm	
hrúbka steny		1 - 11 mm	
Stav		H111	H14
		mäkký	tvrdý
Pevnosť v ťahu (MPa)		60 - 90	100 - 135
Ťažnosť min. (%)	A50	22	5
	A	25	6

Material:	material Al 99,5% in accordance to standard EN 573-3, AW 1050A
Delivered by conditions:	soft H111 hard H14
Surface treatment:	without treatment - natural color (silver) powder coating (different colors) anodic oxide coating - natural color (silver)
Product range:	outer diameter 8 - 60 mm ($\varnothing 6 - 8$ mm after agreement with customer) wall thickness 1 - 11 mm (e - 0,75 - 1mm after agreement with customer) maximal total length of drawn tube is 6 000mm.
Technical conditions for inspection and delivery:	EN 734-1
Mechanical propertis:	EN 754-2

Material standard		EN 573-3, AW 1050A Al 99,5%	
Outer diam.		8 - 60 mm	
wall thickness		1 - 11 mm	
Temper		H111	H14
		soft	hard
Tensile strength (MPa)		60 - 90	100 - 135
Elongation min. (%)	A50	22	5
	A	25	6



Ťahané rúrky zo zliatiny hliníka Aluminium alloy drawn tubes

Materiál:	AlMgSi 0,5% podľa EN 573-3, AW 6060
Podľa požiadaviek:	stav vytvrdený za studena, tvárnený za studena, stav T4 tvárnený za studena, vytvrdený za tepla, stav T6 maximálna dĺžka ťahaných rúr je 6 000 mm
Povrchová úprava:	bez úpravy – prírodný odtieň (strieborná farba) práškovanie (rôzne farebné odtiene) anodická oxidácia – prírodný odtieň (strieborná farba)
Rozmerový sortiment:	vonkajší priemer 8 – 40 mm hrúbka steny 1 – 7 mm
Technické dodacie normy:	EN 754-1
Mechanické vlastnosti:	EN 754-2

Materiálová norma		EN 573-3, AW 6060 AlMgSi 0,5	
Vonkajší priemer hrúbka steny		8 – 40 mm 1 – 7 mm	
Stav		T4	T6
		tvárnený za studena vytvrdený za studena	tvárnený za studena vytvrdený za tepla
Pevnosť v ťahu (MPa)		min. 130	min. 215
Ťažnosť min. (%)	A50	13	10
	A	15	12

Material:	AlMgSi 0,5% standard EN 573-3, AW 6060
Delivered by conditions:	cold hardened, cold formed according to temper T4 cold formed and heat treatable according to temper T6 maximal total length of drawn tube is 6 000mm.
Surface treatment:	without treatment – natural color (silver) powder coating (different colors) anodic oxide coating – natural color (silver)
Product range:	outer diameter 8 – 40 mm wall thickness 1 – 7 mm
Technical conditions for inspection and delivery:	EN 734-1
Mechanical properties:	EN 754-2

Material standard		EN 573-3, AW 6060 AlMgSi 0,5	
Outer diam. wall thickness		8 – 40 mm 1 – 7 mm	
Temper		T4	T6
		cold formed cold hardened	cold formed hardened by heat
Tensile strength (MPa)		min. 130	min. 215
Elongation min. (%)	A50	13	10
	A	15	12

Poznámky
Notes
Bemerkungen



PROJEKT Z EURÓPSKEHO FONDU



Tento projekt sa realizuje s podporou

EURÓPSKEJ ÚNIE

Európsky fond regionálneho rozvoja

Investícia
do vašej budúcnosti



OPERACNÝ PROGRAM
KONKURENCIESCHOPNOSŤ
A HOSPODÁRSKY RAST



**Zavedenie inovatívnych a vyspelých technológií pri
výrobe drôtov a vodičov na báze hliníka**

Prijímateľ:	Laná a.s.
Začatie projektu:	03/2015
Ukončenie projektu:	12/2015
Výška poskytnutého NFP:	2.018.350,00 EUR

www.economy.gov.sk
www.siea.gov.sk



Laná'

Laná, a.s.
 Priemyselná 12
 965 63 Žiar nad Hronom
 Slovenská republika

tel.: 00421/45/601 5026
 fax: 00421/45/601 5306
 e-mail: lana@lana.sk
 www.lana.sk

© 2016 Laná, a.s.